



*An Online CPD Course
brought to you by
CEDengineering.ca*

Detection for Traffic Signals

Course No: C02-057

Credit: 2 PDH

Jeffrey W. Buckholz, Ph.D., P.E., PTOE



Continuing Education and Development, Inc.

P: (877) 322-5800

info@cedengineering.ca

This Traffic Signal Operations course presents information regarding vehicle and pedestrian detection systems used in modern traffic signal control. The material is intended to provide a practical overview of detection types, components, and operational characteristics. This is not an introductory course and a basic knowledge of traffic signal operation is assumed.

Vehicle detection is used for a variety of traffic control purposes. Detectors are used to:

- Count vehicles;
- Operate gates at exits of parking garages and other restricted entrances;
- Control vehicles entering a freeway ("ramp metering");
- Provide incident detection on freeways by measuring speeds and other traffic characteristics;
- Provide Automatic Vehicle Identification (AVI) for automatic toll collection;
- Provide emergency vehicle detection for use in signal preemption; and
- Control actuated traffic signals.

By far the most common use for vehicle detection is in the control of actuated traffic signals. Consequently, we will concentrate on traffic signal detection in this chapter.

Detector assemblies used in traffic signal operation have three basic components:

1. The **field unit** (also called the "sensing unit"): This device which detects the traffic. It might be buried in the pavement below a roadway lane or might be mounted overhead. The portion of the travel lane for which the field unit provides detection is called the **detection area**.

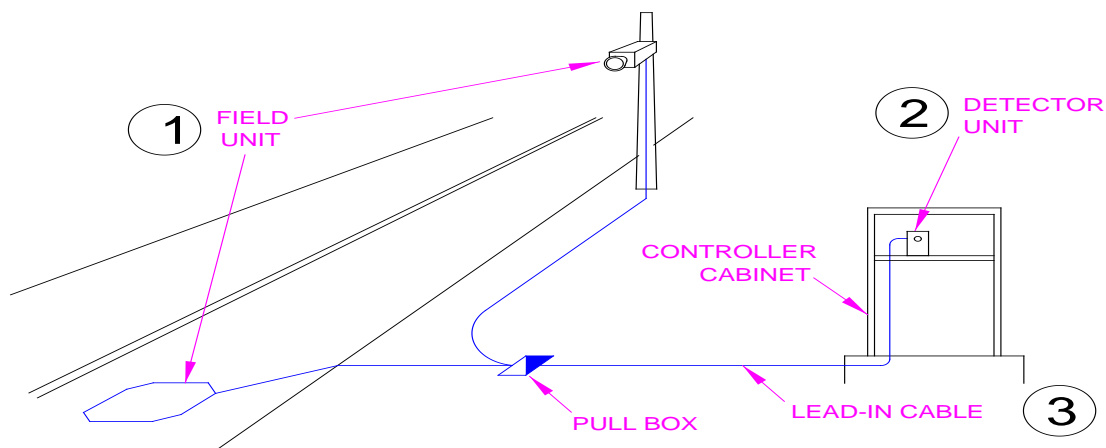

2. The **detector** amplifier (also called the "detector unit" or simply the "detector"): This device receives traffic detection information from the field unit and converts this information into an electrical impulse that the traffic signal controller can recognize.
3. The **lead-in cable**: This device connects the field unit to the detector. The lead-in cable is also commonly called the "home-run" cable or "feeder" cable. Wireless detection has no lead-in cable but rather uses radio signals to transfer detection signals from the field unit to the detector unit.

Short or long detection areas, or some combination, may be used for signalized intersection control. Although there is no strict definition, short detection areas are typically less than 25 feet long in the direction of travel while long detection areas are typically greater than 25 feet long.

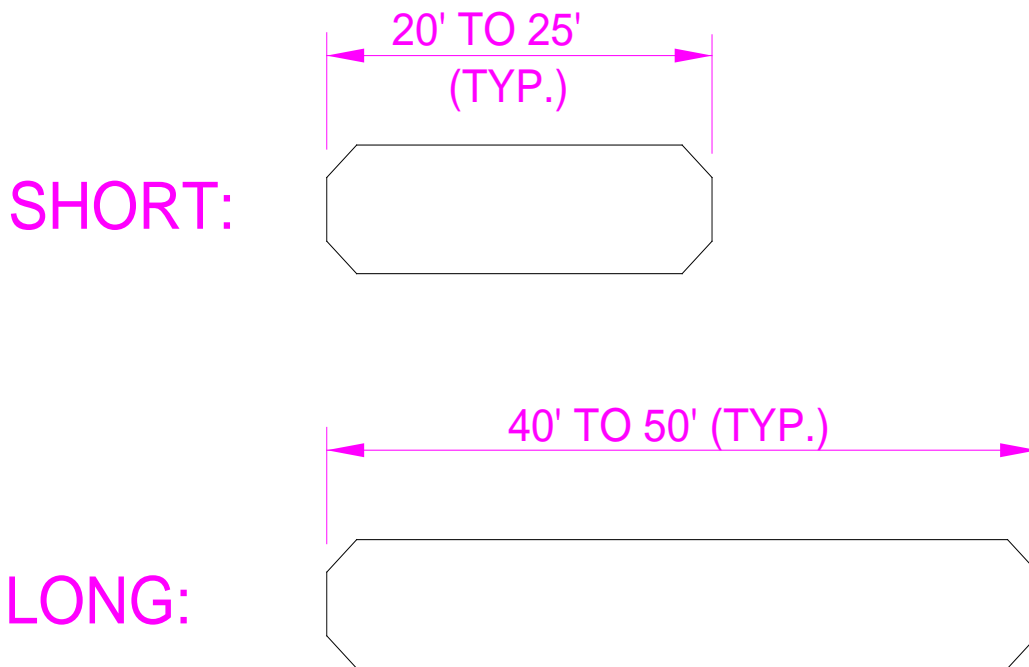

Short detection areas are typically less expensive and easier to construct than long detection areas. In addition, they are quite suitable for certain types of detection designs, such as those used on high speed approaches. Long detection areas have certain operational advantages when used on lower speed approaches and in left turn lanes.

Detection areas may be located either in the vicinity of the stop line or some distance upstream from the stop line.

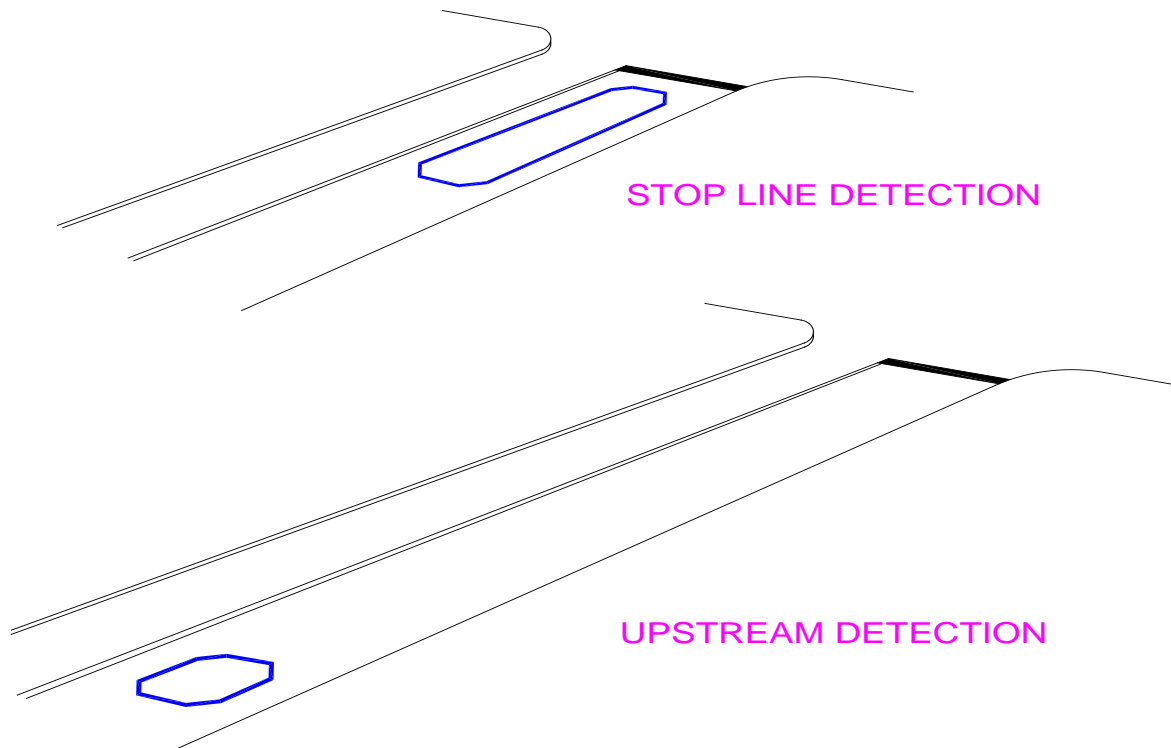

Upstream detection is typically used on higher speed approaches to provide dilemma zone protection (to be discussed later) while stop line detection is typically used on lower speed approaches and in left turn lanes. It is common to find short, upstream detection areas on the high speed approaches to an intersection and long, stop line detection areas on the lower speed approaches, and in the left turn lanes.

When a detector assembly senses a vehicle, it sends a "call" to the traffic signal controller (by means of an electrical impulse). A call is essentially a demand for the green interval on the phase which that detector assembly is connected to. If the controller is currently providing the green indication to that phase, then the call will usually extend the green on that phase. If the green is currently being displayed on another phase, then the call will cause the controller, at some appropriate time, to transfer the green to the phase being called. The exact reaction of the controller to the call depends on many factors, including the controller settings, the current state that the controller is in, and the status of calls received from other detector assemblies.

LOCKING VERSUS NON-LOCKING OPERATION

When a controller phase is set to locking operation (also called "memory on" or "locked call" operation), the controller will "remember" any vehicle calls that it receives, even if the vehicle has left the detection area.

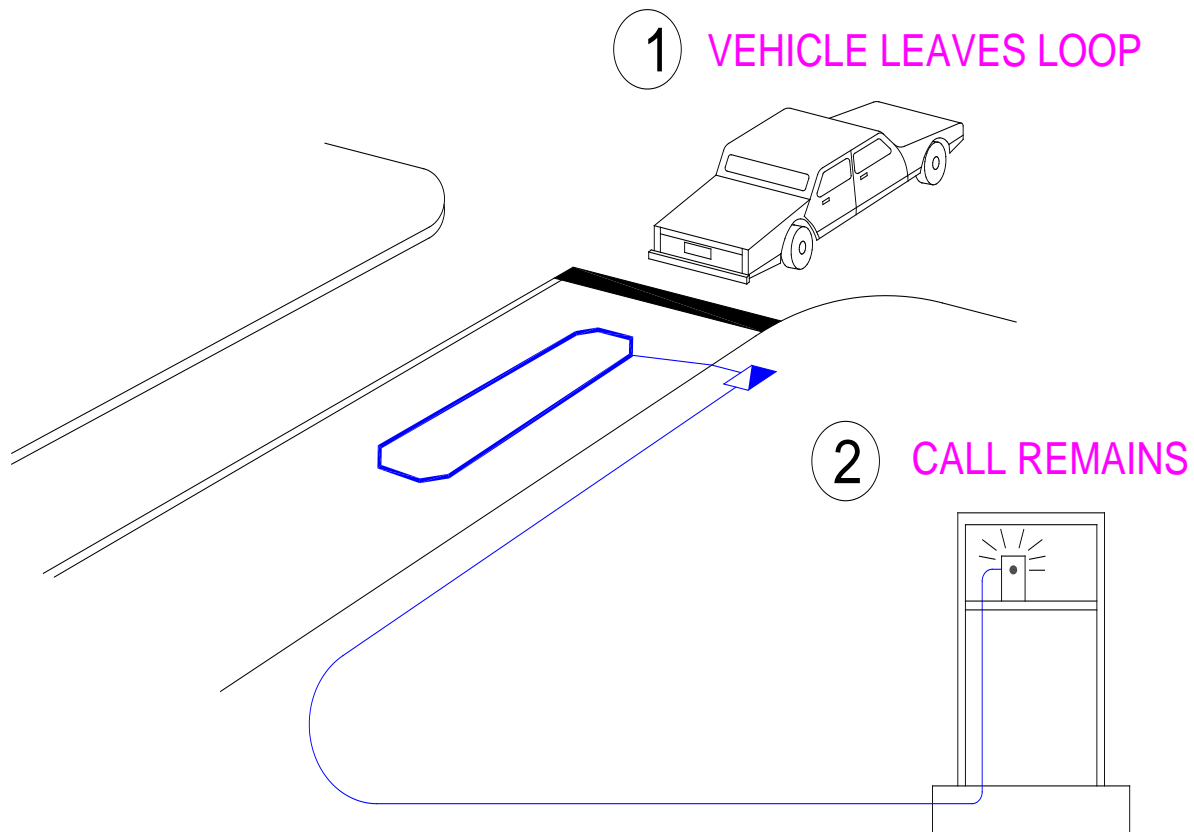

If the phase does not currently have the green, then a demand for service will remain on that phase until the phase receives the green, at which time the call will be removed.

Locking detection is used to remember vehicles which may pull past the detection area. If these vehicles were not "remembered" they could become trapped between the intersection and the detection area and never receive the green. Consequently, locking detection is often used with upstream detection areas. Locking detection may be used with stop line detection if motorists frequently pull so far past the stop line that they leave the detection area. These vehicles could also become trapped if they are not remembered.

The major drawback to locking operation is that it can result in false calls for the green that waste valuable green time. This can occur under the following circumstances:

- A vehicle traverses the detection area, placing a call for the green, and then turns right before it receives the green (right-turn-on-red). The vehicle is remembered even though it is no longer at the intersection and the green is falsely displayed to an empty approach.
- A vehicle has the green and is traversing the detection area when the signal turns yellow. The motorist continues through the intersection on the yellow. Since locking operation for a phase is active whenever the signal indication for that phase is not green (which includes the yellow interval and the red interval) the vehicle is remembered and the green is falsely displayed to an empty approach.

When a controller phase is set to non-locking operation (also called "memory off" or "non-locked call" operation), the controller will not remember vehicles that have left the detection area and the call for the green will disappear once the vehicle leaves the detection area. Although non-locking operation does not produce the type of false calls for the green that locking operation produces, non-locking operation can result in motorists being trapped between the intersection and the detection area if the detection area is not properly designed.

It should be noted that it is quite common to have some phases set for locking operation and others set for non-locking operation at the same intersection.

MOTION VERSUS PRESENCE DETECTION

There are two basic types of vehicle detection:

- Motion Detection (also called "pulse" detection), and
- Presence Detection.

A detector assembly that provides motion detection sends a momentary call (called a "pulse") to the controller when it senses the presence of a vehicle within the detection area. If the phase is currently green, the green period will be extended by this call. However, if the phase is currently red, then the controller must be set for locking operation or the call will not be retained. Long detection areas are of no advantage

when motion detection is used. Consequently, motion detection is almost always associated with short detection areas.

A detector assembly that provides presence detection sends a call to the controller as long as some part of the vehicle is within the detection area.

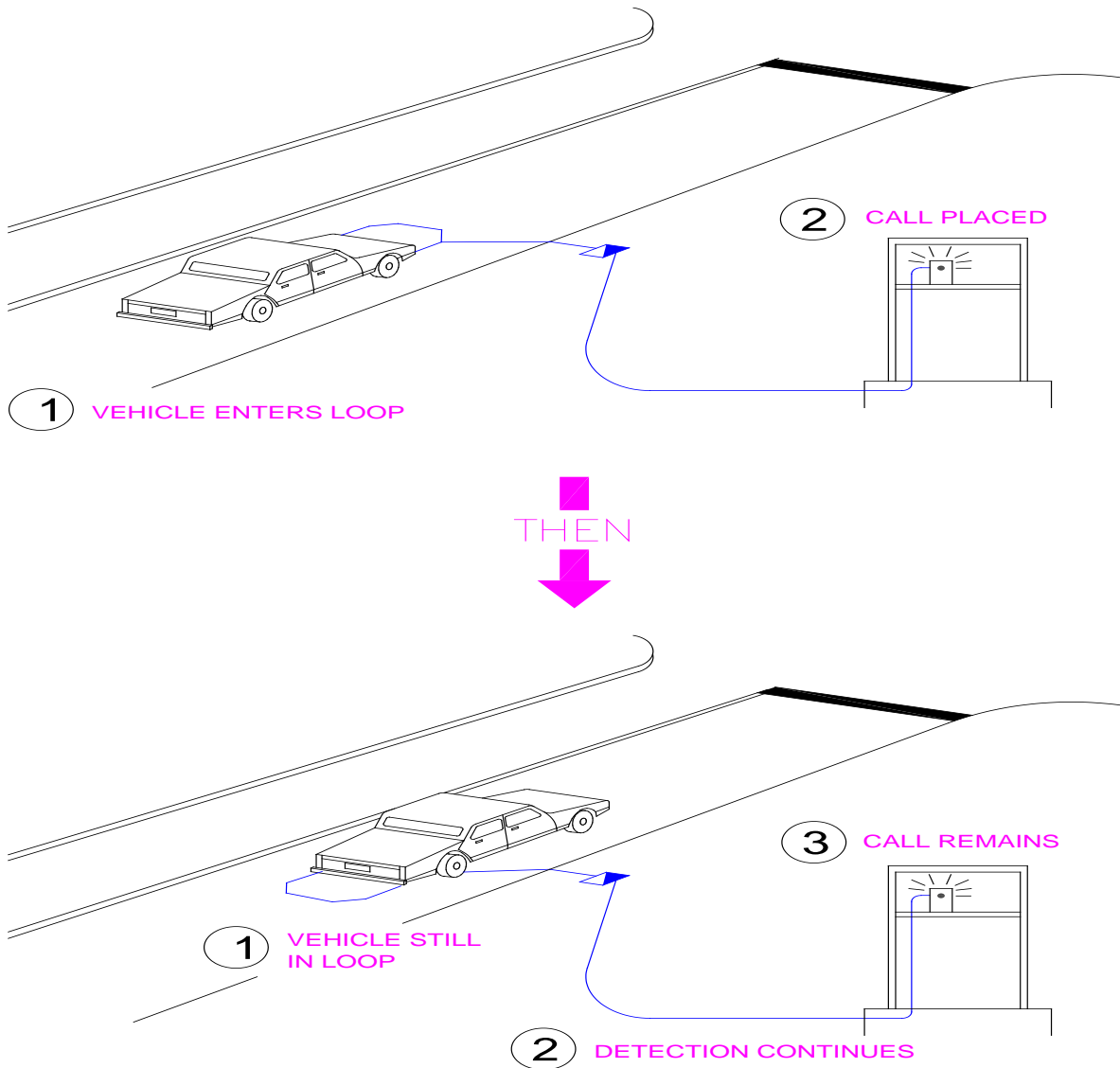

The call will not "drop" (cease) until the vehicle totally vacates the detection area. If the phase is currently green, then the green period will be extended by this call. If the phase is currently red, then the controller will continue to recognize the call as long as the vehicle is in the detection area. Presence detection is typically associated with long stop line detection areas programmed for non-locking operation.

COMMON TYPES OF VEHICLE DETECTOR ASSEMBLIES

Current vehicle detection technology can be divided into the following three areas:

1. Detection devices having field units located in or under the pavement
2. Non-video detection devices mounted overhead
3. Video detection devices mounted overhead

There are a number of different detection devices that can be embedded in or buried under the pavement (in-roadway sensors). Although various devices have been used in the past, including treadles and pressure pads, modern alternatives include:

- Inductive Loops
- Magnetic Detectors,
- Magnetometers,
- Microloops, and
- Wireless Magnetometers

Inductive loops are by far the most common type of detection device in use today.



They consist of a loop of wire buried in the pavement that, when connected to an inductive loop detector unit, senses the presence of a vehicle by detecting changes in inductance caused by the vehicle's presence. They are capable of providing both presence detection and motion detection.

Magnetic detectors sense traffic by detecting disturbances in the earth's magnetic field. They are motion detectors only and are incapable of providing presence detection, which is a critical drawback for traffic signal operation.

Magnetometers also sense traffic by detecting disturbances in the earth's magnetic field; however, they are capable of providing presence detection as well as motion detection.

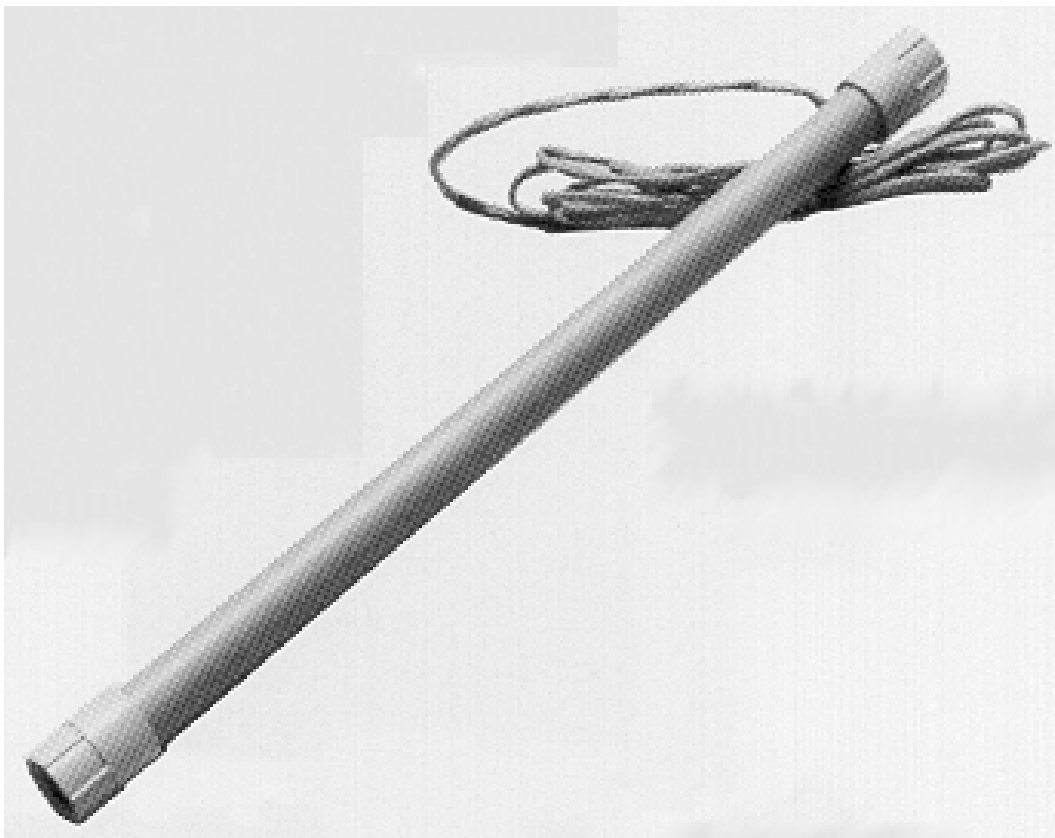

Since the detection area of an individual magnetometer is relatively small in size, a number of magnetometers must be used to provide the same detection coverage as an inductance loop.

Microloops are very similar to magnetometers. The major difference is that they can be used with properly configured inductive loop detector units, whereas magnetometers and magnetic detectors require the use of special magnetic detector units. Microloops can be installed in the pavement or, using schedule 80 conduit, under the pavement. The Microloop is a proprietary item owned by Global Traffic Technologies.

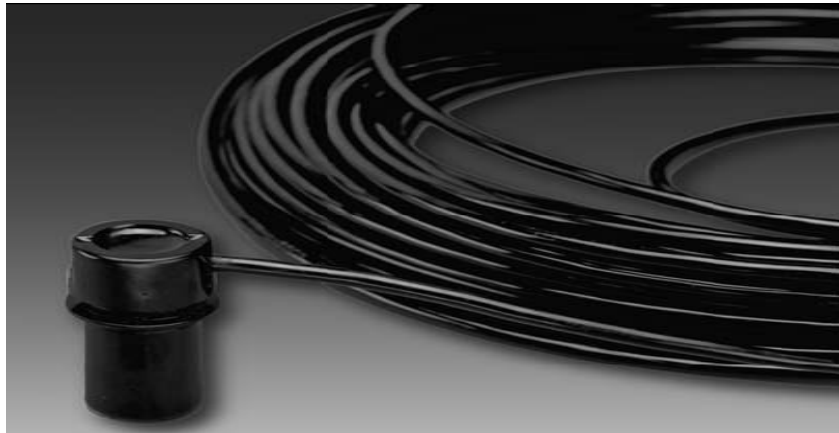

New on the detection scene are wireless magnetometers that have the advantage of requiring no physical connection (wire) between the field unit (the magnetometer) and the detection unit. The wireless magnetometers, which operate over the unlicensed 2.4 GHz frequency band, are powered by an internal battery that requires replacement about once every 10 years.



Non-video overhead detection devices are those that do not use video cameras for detection.



As is the case with underground detection, there are a number of different non-video technologies that can be used in overhead applications to provide vehicle detection inputs for actuated signal control:

1. Microwave Radar,
2. Active Infrared (Laser Radar)
3. Passive Infrared
4. Ultrasonic
5. Passive Acoustic

Various devices are available that employ one or more of these technologies to achieve reliable presence detection. For example, this unit uses a combination of infrared and ultrasonic technology for vehicle detection:



Whereas the detector unit for buried detection is typically located in the controller cabinet, the detector unit for overhead installations is often an integral part of the field unit. In these overhead installations, the lead-in wire does not connect the field unit to the detector, but rather connects the field unit/detector assembly to the controller or to some other pre-processor located in the controller cabinet.

With overhead mounting, much flexibility is provided for establishing the detection area. The "detection window" of the overhead device can usually be set to cover one or many lanes and can also be set to provide for a short or long detection area.

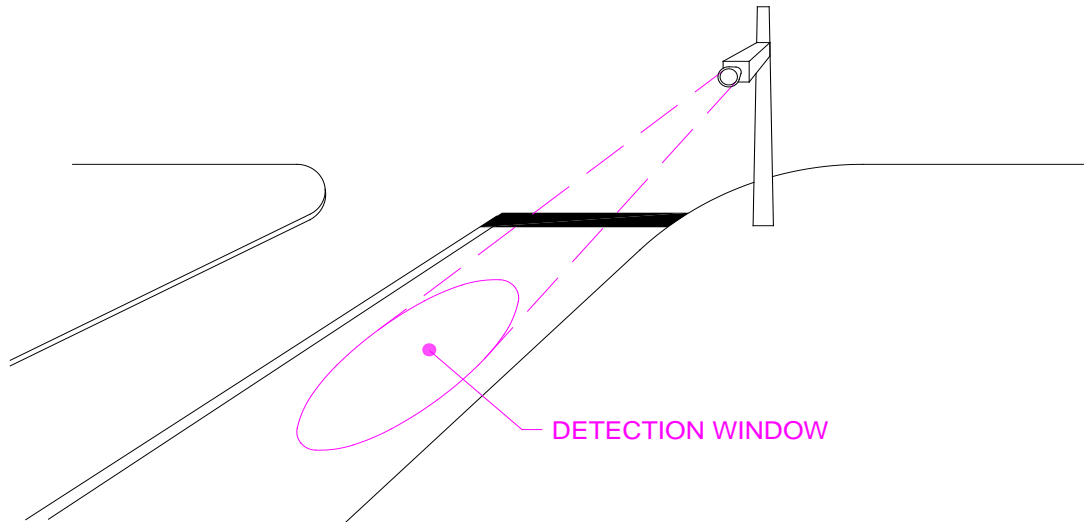

In order to have a stable detection area, the unit must be mounted overhead on a pole; it cannot be allowed to swing free on a span wire if reliable detection is to be provided. Overhead detection units are typically mounted directly over the travel lane on a mast arm, or are mounted off to the side of the lane on a pole. However, at wide intersections, providing accurate detection for main street left turn lanes can be difficult unless long mast arms are present or a median pole exists.

Overhead devices (over-roadway sensors) can be an attractive detection alternative for intersections that are under construction since paving operations or excavation work can repeatedly disable field units that are embedded in the pavement. Construction activity may also sever lead-in wires that connect buried field units to the detector units.

It should be noted that two additional technologies, radio frequency transmission and high intensity light, are commonly used in overhead installations to detect emergency vehicles for traffic signal preemption. Emergency vehicle preemption of traffic signals can be provided using overhead mounted optical detectors which receive an optical signal from a high intensity light source mounted on the emergency vehicle.

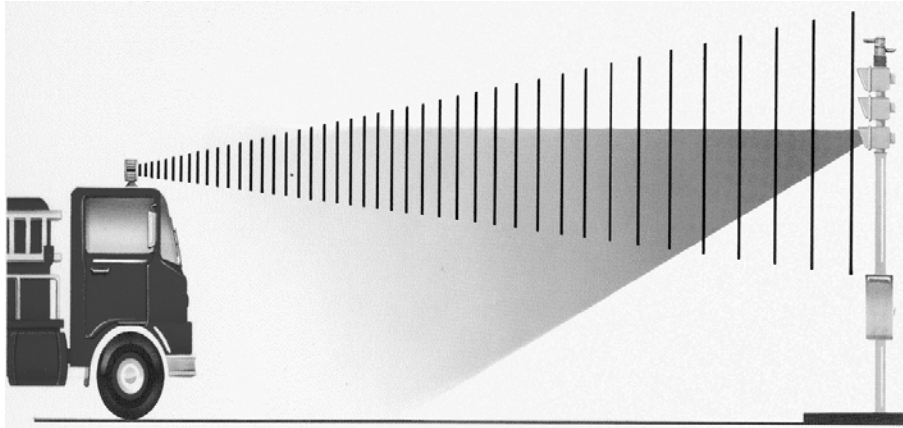

When the optical signal is received, the detector will cause the traffic signal controller to implement a special preemption plan that provides the green indication in the direction of the approaching emergency vehicle. Emergency vehicle preemption of traffic signals can also be provided using radio technology. Receivers mounted overhead, activate a special preemption plan whenever they receive a radio frequency signal from the transmitter mounted on the emergency vehicle, providing the green indication in the direction of the approaching emergency vehicle.

Video imaging devices are overhead units that use video cameras for vehicle detection.



These systems are quite sophisticated, using machine vision and complex computer algorithms to evaluate changes in the video image which indicate the presence of a vehicle. Accurate detection requires that the system be able to operate successfully in all kinds of weather and under a variety of ambient light conditions.

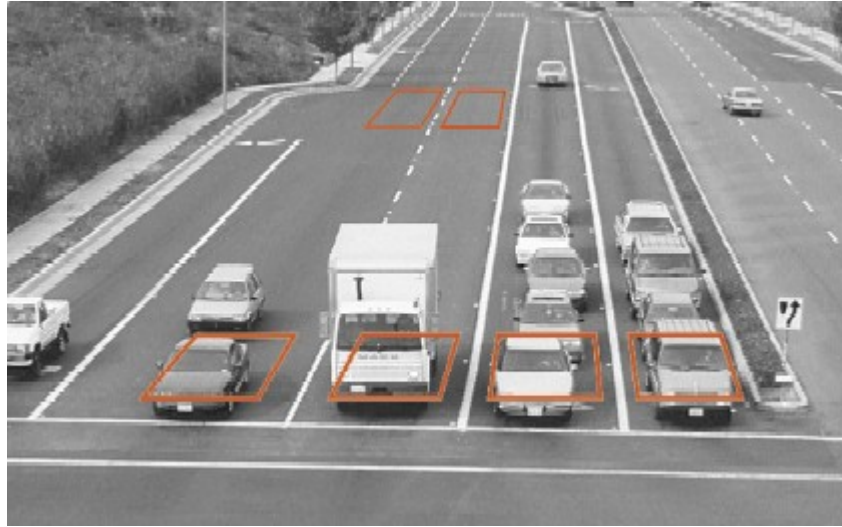

Although the capabilities of video detection systems have increased dramatically in recent years, certain conditions, such as heavy fog or rainy night conditions can still produce detection problems. Video detection systems are capable of both motion and presence detection.

Both video and non-video overhead detection devices are somewhat susceptible to spurious activation by pedestrians and animals, which could result in false calls for the green. Buried detection units are unaffected by these items.

INDUCTIVE LOOPS

Since inductive loops are the most common form of vehicle detection, the discussion of vehicle detection provided in the remainder of this course will reference inductive loops. However, it should be kept in mind that this discussion is generally pertinent to any type of detection system.

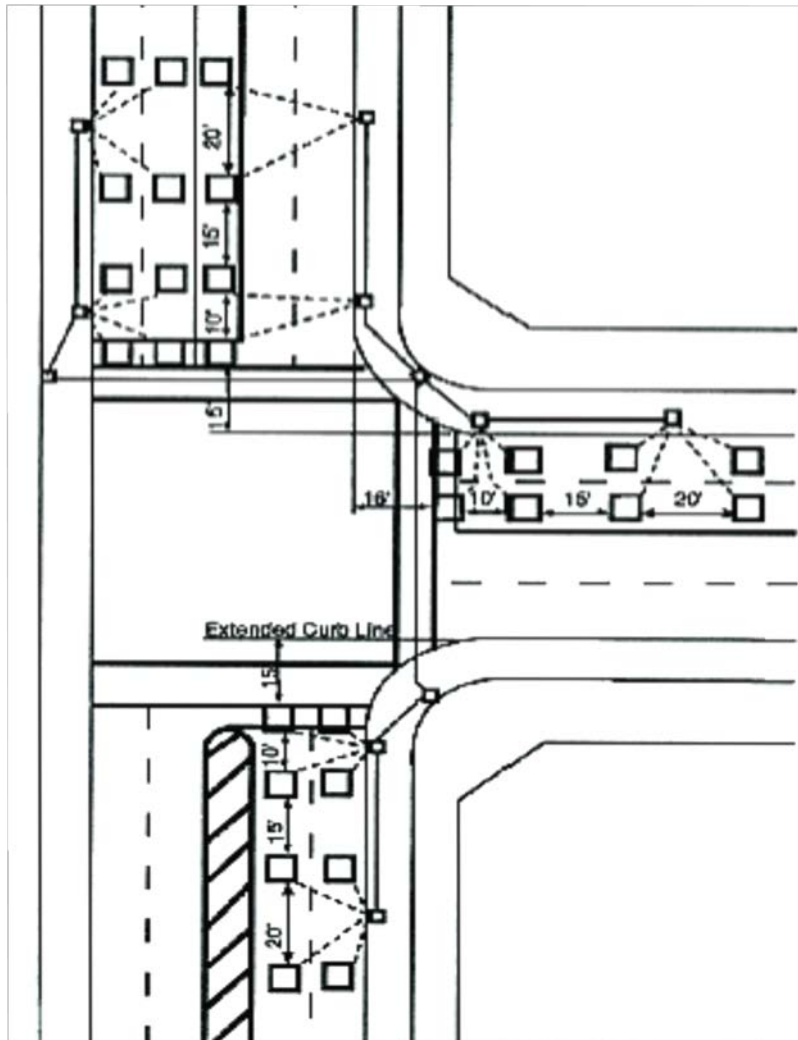

Fully actuated traffic signals usually require the use of numerous vehicle detector assemblies. There is almost always at least one loop for each phase of the controller, and often there is a loop for each approach lane at the intersection. In some cases, multiple loops are used in certain lanes.

Loops may be connected to the detectors in a variety of ways:

- Each loop may be connected to a separate detector amplifier.
- All loops in the same lane may be connected to the same detector amplifier.
- All loops providing detection for the same phase may be connected to the same detector amplifier.
- Some combination of the above may be implemented.

Although inductive loops come in many shapes and sizes, common types in use include:

- Square loops,
- Multiple square loops (an “array”),
- Rectangular loops,
- Quadrapole loops,
- Parallelogram loops, and
- Trapezoid loops.

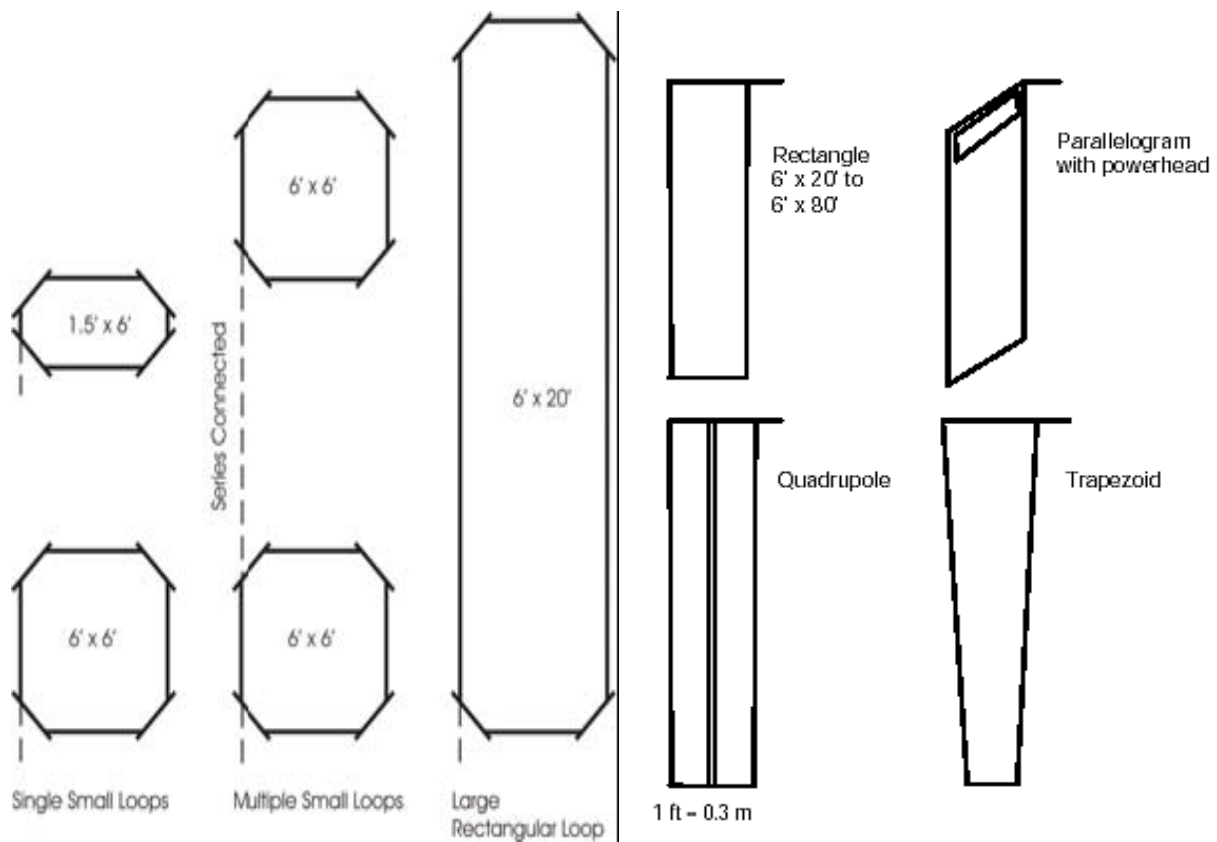

Unless the loop is located close to the controller cabinet which houses the detector (less than 75 feet is a rule-of-thumb), the loop wire should be spliced to a shielded lead-in cable before it is run to the cabinet to avoid a type of electrical interference known as “crosstalk”.

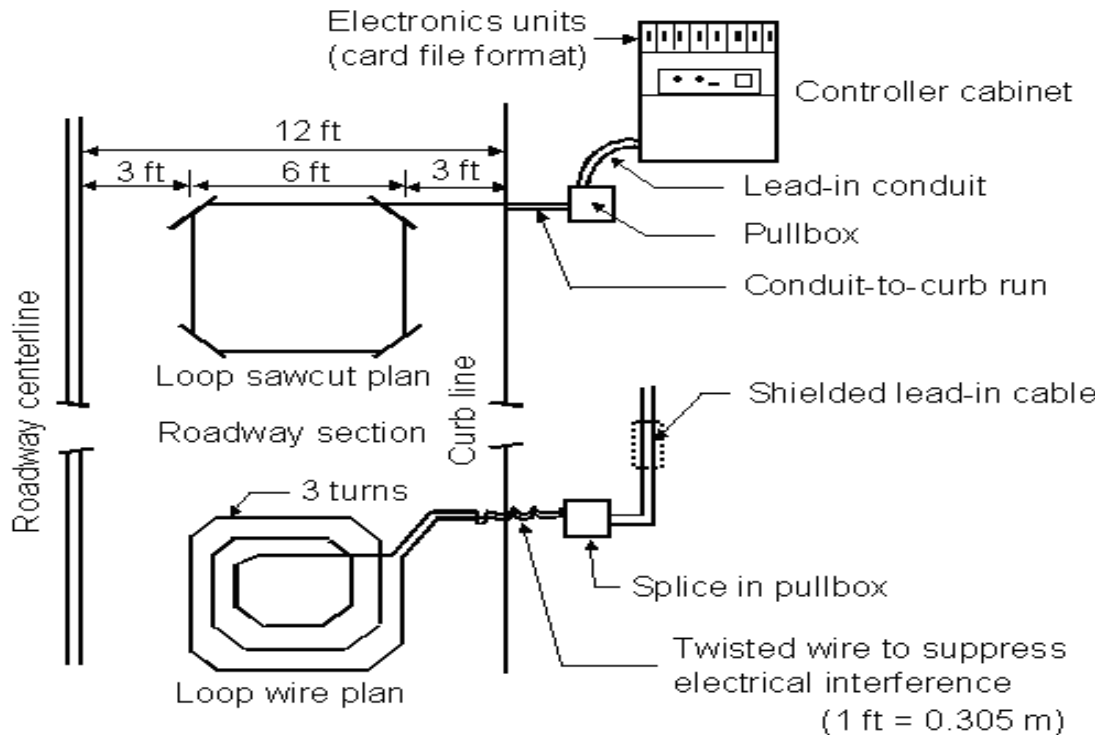

Between the loop and the lead-in cable, the unshielded loop wire should be twisted at no less than 5 twists per foot. Twisting the wires cancels their inductance field, ensuring that inappropriate vehicle detections do not occur.

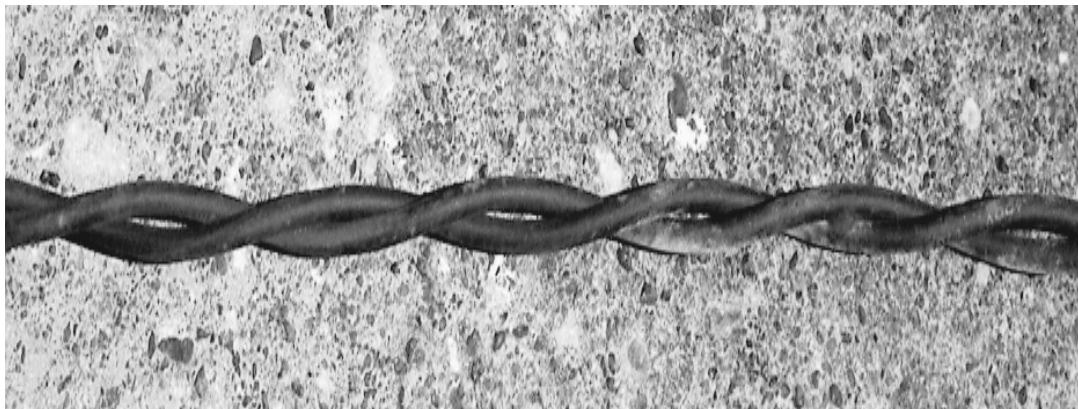

Shielded lead-in cable is typically constructed of number 14 or number 12 AWG (American Wire Gauge) wire that is twisted at approximately 15 twists per foot, covered by an aluminum-polyester shield, and encased in a continuous PVC (PolyVinyl Chloride) outer jacket.

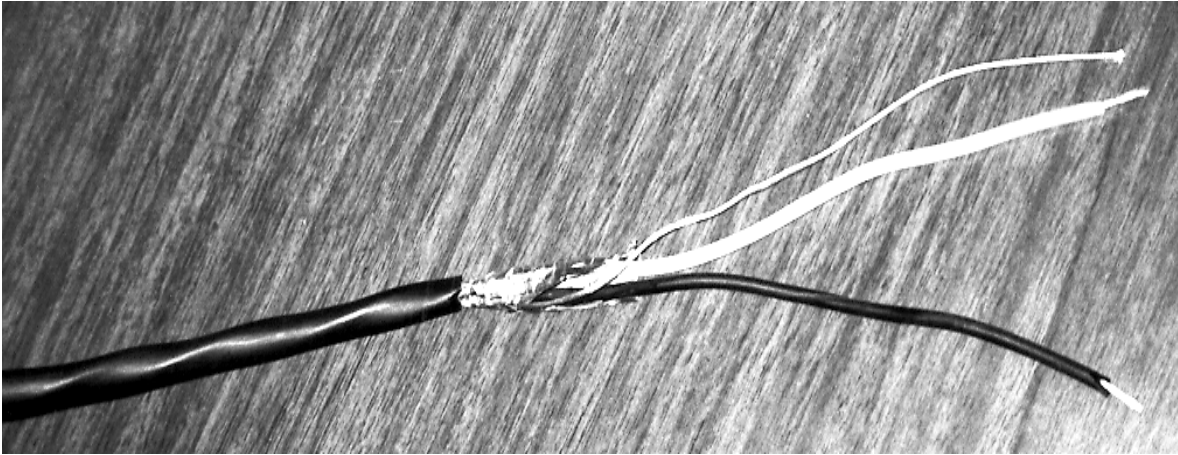

This construction allows loop wires for different detectors to run in the same conduit for long distances without causing interference problems.

The splice between the loop wire and the shielded lead-in cable is a potential weak point in the loop circuit and must be carefully constructed. Soldering of the connection is highly recommended, as is encapsulation of the soldered connection within a waterproof sealant.



LOOP INDUCTANCE

As their name suggests, inductance loops sense the presence of vehicles by detecting changes in an inductance field created by the loop when a vehicle disturbs that field. Electricity flowing through the loop at a specified frequency creates this inductance field, which rises up from the pavement.

The inductance of a loop increases with increasing loop size and with the number of "turns" in the loop. The number of "turns" is the number of times that the loop wire is wound around within the saw cut. A calculated inductance chart shows the expected inductance of loops having different sizes and turns of wire:

Inductance Values (in Microhenries) for a Loop Operating at a Frequency of 50kHz				
Loop Type	Loop Size	2 Turns	3 Turns	4 Turns
Rectangular	6' x 6'	36	74	125
	6' x 20'	84	175	298
	6' x 50'	187	401	712
Quadrapole	6' x 6'	61	127	214
	6' x 20'	177	378	662
	6' x 50'	447	1073	2511
Circular	6' diameter	29	60	101

The inductance of the lead-in cable is typically assumed to be about 0.23 microhenries per foot. Since the lead-in cable is connected in series with the loop, the inductance of the lead-in must be added to the inductance of the loop to determine the combined inductance of the loop/lead-in assembly. Fifty (50) feet of lead-in wire added to the end of a 6' x 20', 3-turn rectangular loop produces a total inductance for the loop assembly of 187 microhenries.

NEMA standards require detector amplifiers to tune to inductances between 50 and 700 microhenries (at 50 kHz). Consequently, the shaded values in the inductance chart are outside the NEMA inductance range and would not be acceptable. The 2-turn 6' x 6' rectangular loop assembly could be made acceptable by adding at least 61 feet of lead-in cable.

In order to provide better detection of smaller vehicles, such as motorcycles, various techniques can be used to increase the sensitivity of the loop:

- Provide loops with sharp angles, such as trapezoidal loops instead of rectangular loops, or octagon-shaped loops instead of square loops, since sharp angles increase the strength of the inductance field in the vicinity of the angle.



- Use quadrupole loops which, because of the figure 8 pattern in which the loop wires are wound, have a very strong field at the center of the loop.



- Use power heads, which provide additional turns of wire at the front end of the loop, thus increasing loop sensitivity in this area.



In addition, modern detectors typically have a switch that allows the user to increase the sensitivity of the loop.

The height of a loop's vertical detection field over the road surface is essentially equal to $\frac{2}{3}$ of the shortest distance between parallel loop saw cuts. For example, the height of detection for a rectangular 20' x 6' loop is approximately 4 feet ($6' \times \frac{2}{3}$) while the height of detection for a 20' x 6' quadrapole loop is about 2 feet ($3' \times \frac{2}{3}$). The shorter detection field of quadrapole loops can be problematic if there is a need to detect vehicles having high road clearance.

Detection spillover (also called splashover) occurs when a loop is located too close to an adjacent lane, or when the loop sensitivity is set too high, causing vehicles in adjacent lanes to be detected. Consequently, the sensitivity of a loop should not be arbitrarily increased to its highest value. Because of the compact shape of their detection field, quadrapole loops are less susceptible to spillover than other loop designs.

Loops are usually 6 feet wide since, when centered in a typical 12-foot traffic lane, this size loop provides good lane coverage while at the same time maintaining enough distance from adjacent lanes to prevent spillover and crosstalk. Crosstalk occurs between loops when the loops are located close together, are of similar size, and are operating on a similar frequency. Under these conditions, loops can activate each other resulting in false vehicle detections.

Crosstalk can also occur if unshielded loop wire from different loop assemblies is run for too long of a distance in the same conduit; greater than 50 feet is a cause for concern. The probability of crosstalk can be reduced by keeping loop wires properly separated and by setting detectors, which control adjacent loops, to different frequencies. Modern detectors typically have a switch that allows the user to select a variety of activation frequencies.

When more than one loop is connected to the same detector, the system of loops that results is called a "multi-loop assembly" or an "array".

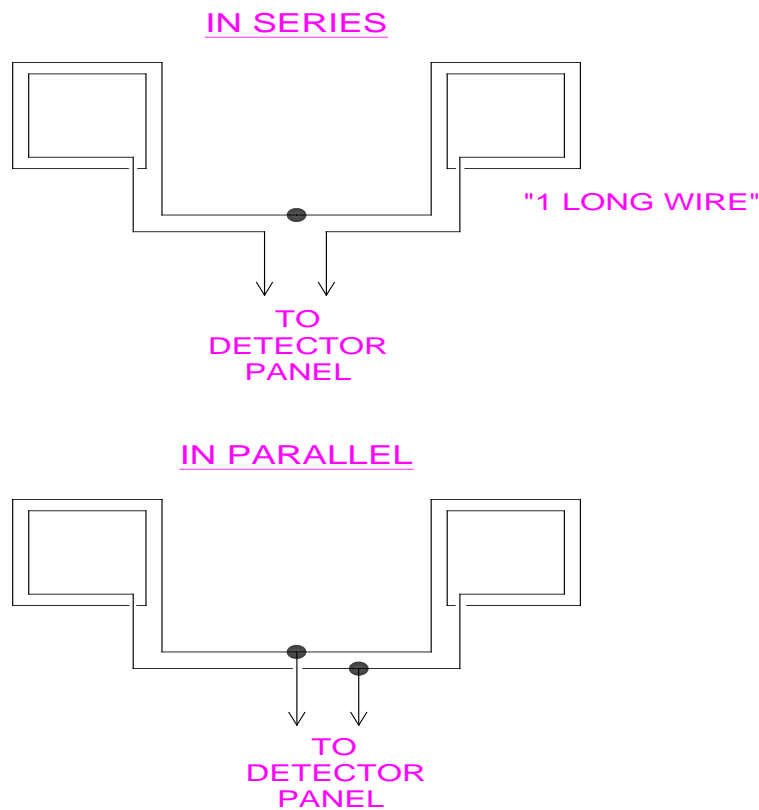

The resulting inductance of this multi-loop assembly depends on a number of factors, including whether the individual loops were connected to one another in series, in parallel, or in some combination. When loops are connected in series the inductance of the assembly increases ($L_T = L_1 + L_2 + L_3 + \dots$) whereas the inductance decreases if the loops are connected in parallel ($1/L_T = 1/L_1 + 1/L_2 + 1/L_3 + \dots$). These effects must be taken into account when calculating the total inductance of a multi-loop assembly.

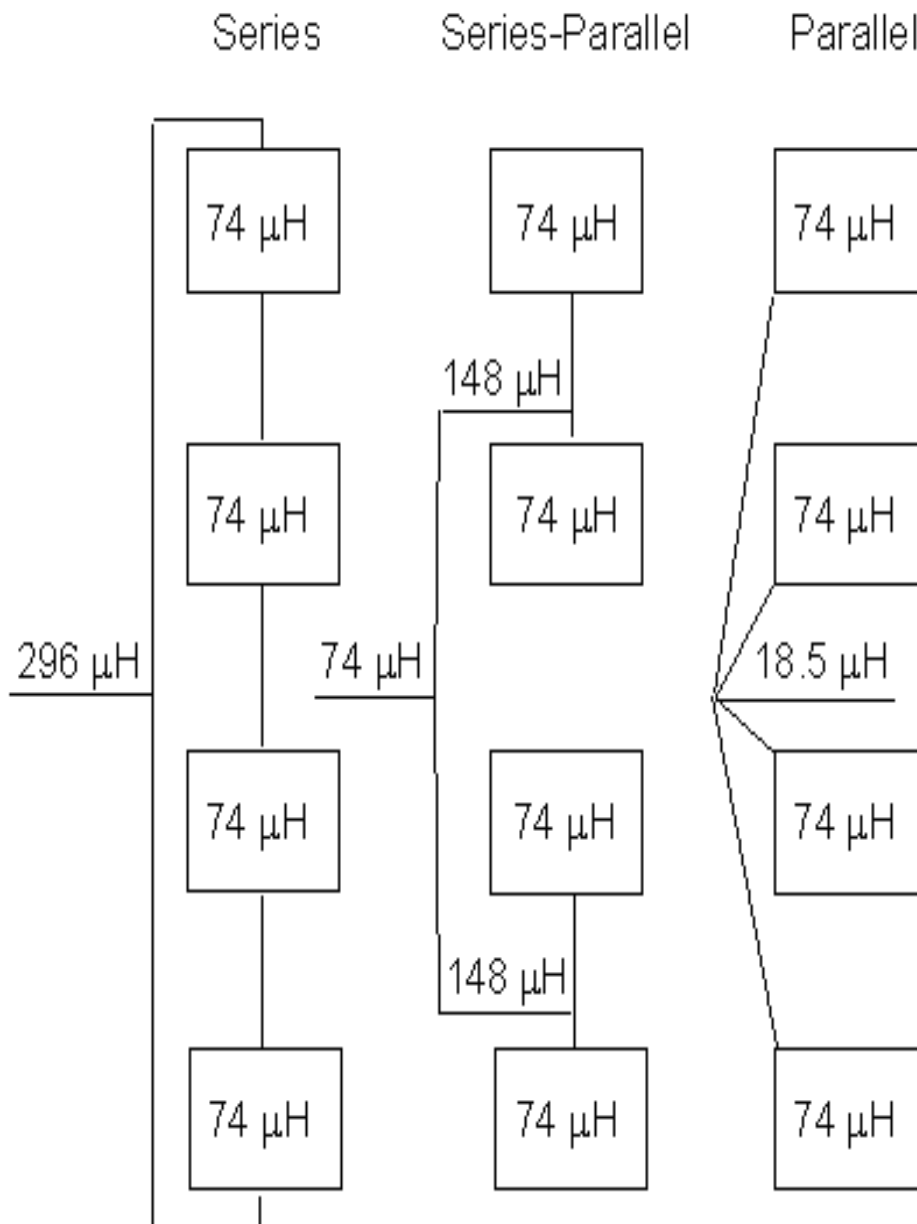

LOOP INSTALLATION

Loops are typically installed by sawcutting slots in the pavement, cleaning out the slot using an air compressor or vacuum cleaner, placing the loop wire in the slot, and wrapping it around to form multiple turns. The wire is usually encapsulated in a flexible, waterproof sealant that is specifically intended for loop construction. Alternatively, the loop may be encased in polyethylene tubing or plastic conduit before being placed in the sawcut.



Inductance loops are typically constructed using number 14 or number 12 AWG (American Wire Gauge) XHHW cross-linked polyethylene wire rated for 600 volts. The depth of the sawcut depends on the number of turns of loop and wire size. As a general rule, a sawcut depth that provides 1 inch of cover is used for concrete pavements and a sawcut depth that provides 2 inches of cover is used for asphalt pavements.

Installing the loop wires in a sawcut that is too shallow reduces the level of protection from the elements while installing the loops too deep can result in reduced sensitivity. Sharp corners that might damage the loop wire insulation are typically eliminated by either installing an angled sawcut at the corners of the loop or by drilling rounded holes at the corners.

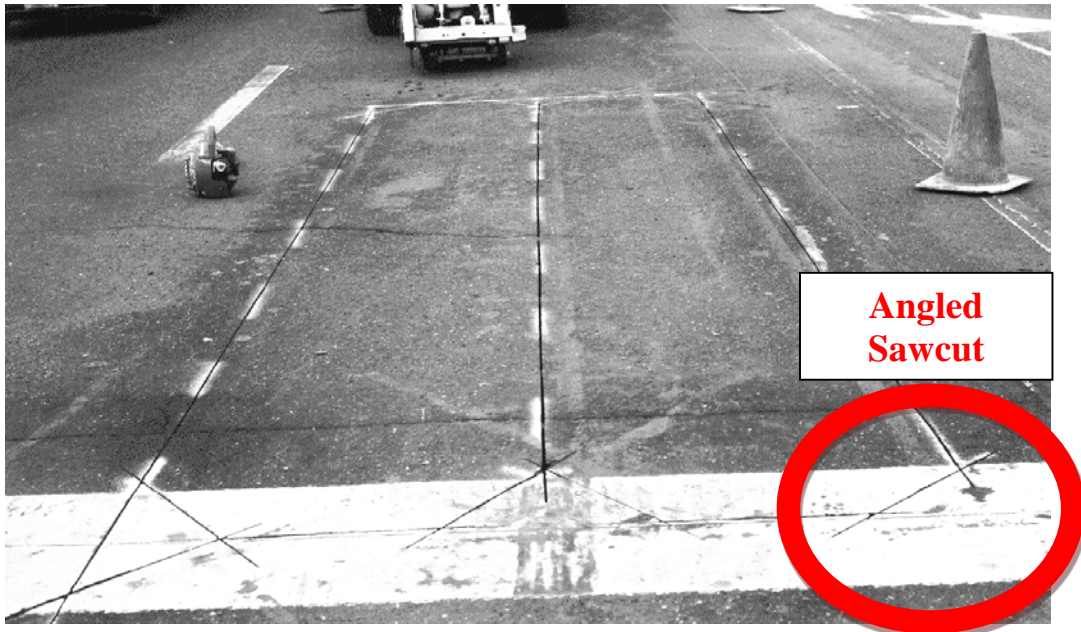

The use of preformed loops has gained popularity in recent years. These loops are typically used where new pavement construction is occurring. The loops are fabricated at a central location, transported to the site, and then installed between pavement layers. With a bit more difficulty, preformed loops can be sawcut into existing pavement. The primary advantage of preformed loops is the consistent quality of their construction.

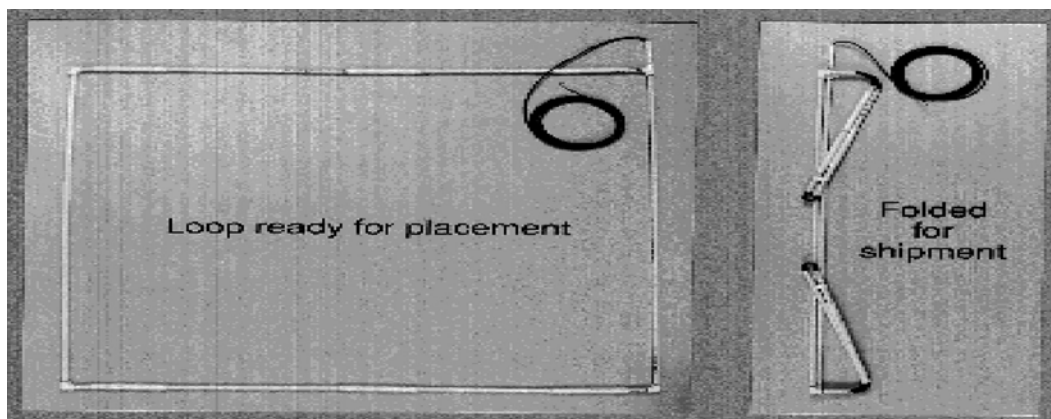

Loop installation should not be attempted without proper work zone traffic control. Since installing the loops will require closing lanes, appropriate advanced signing will be needed and, depending on the situation at hand, so will either a flashing arrow board, a police officer, or properly trained flaggers to aid in traffic control. Keep in mind that additional traffic control measures will need to be taken if the wire from the inductance loop to the nearest pull box must cross other lanes of traffic.



LOOP TESTING

At a minimum, inductance loops should be tested for continuity and for insulation resistance (also called "resistance to ground"). A megohmmeter is typically used to conduct these tests.

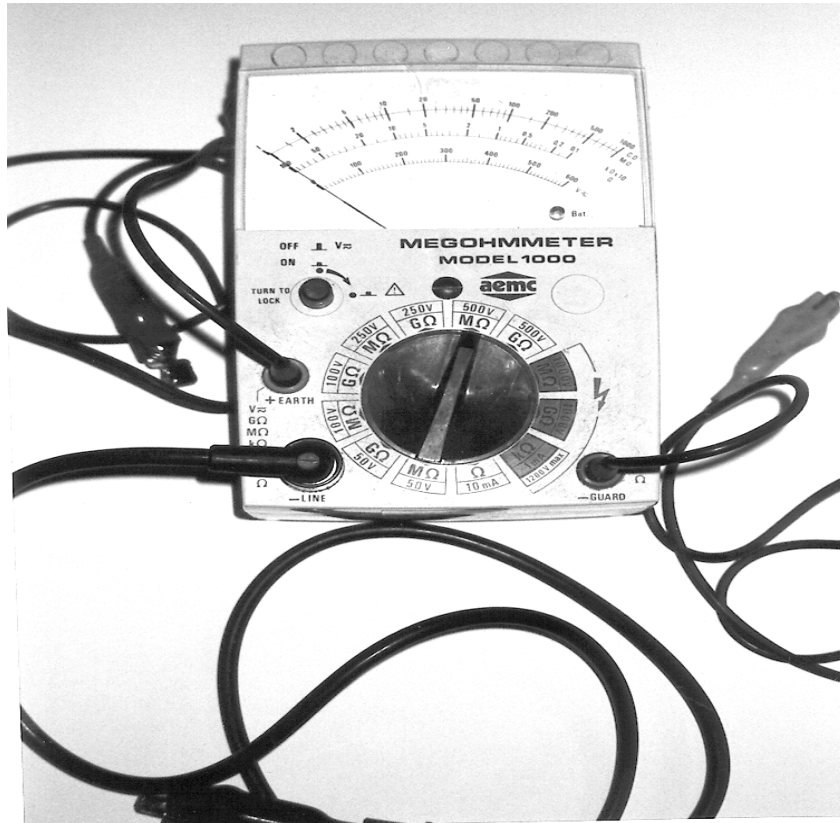

The continuity of the inductance loop assembly is tested by connecting each end of the loop to the meter and reading the resistance of the assembly in ohms. A low resistance (less than 2 ohms) is desired, which is indicative of a continuous loop assembly with no breaks in the wire. A resistance value of greater than 5 ohms is typically considered unacceptable.

The insulation resistance of the inductance loop assembly is tested by connecting the meter to one end of the loop assembly and to the ground wire located in the cabinet. 500 volts is then placed on the circuit and the resistance measured in megohms. A high resistance (greater than 100 megohms) is desired, which is indicative of a loop assembly with no breaks in the insulation and good splices. A resistance value of less than 50 megohms is typically considered unacceptable.

DETECTOR OPERATION

Most detector units for inductance loop assemblies have a fail-safe mode of operation which causes the detector to fail "on" (giving a constant call) if there exists either an open or shorted loop circuit. Failing "off" would be unacceptable since it would cause motorists to never receive the green indication.

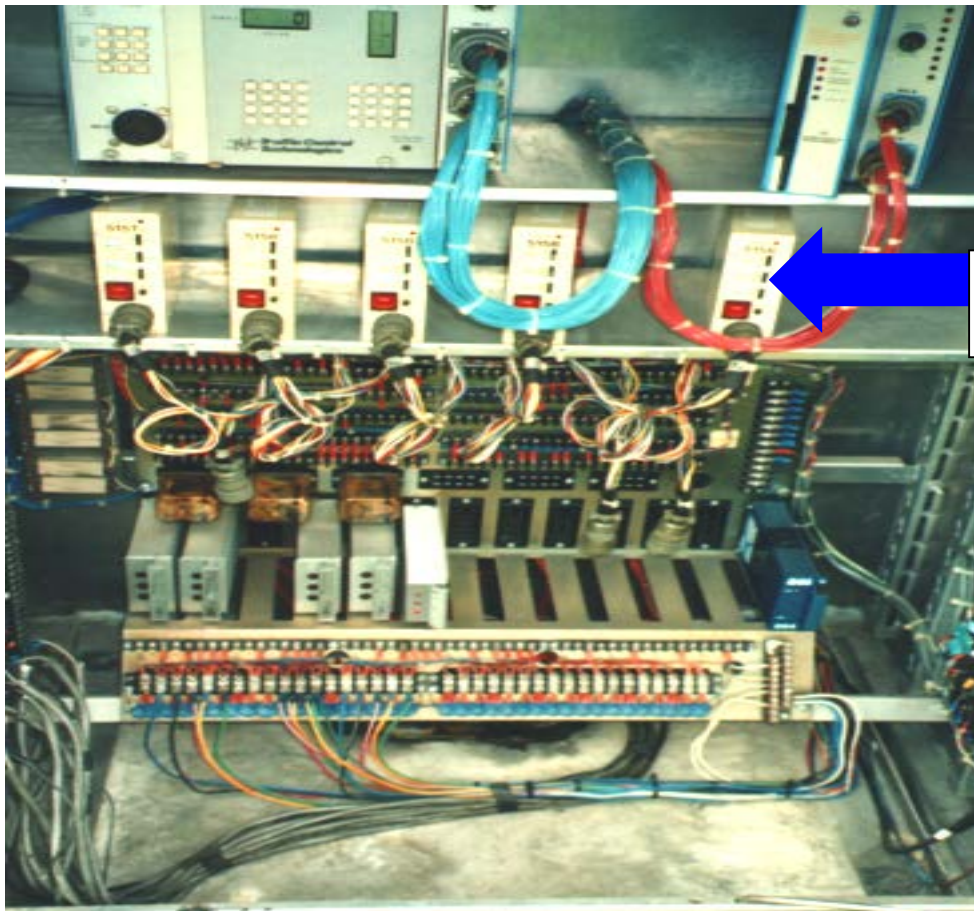

**5 Stand-Alone
Detector Units**

Detectors can be purchased which provide for the delayed detection of vehicles. Once a vehicle enters the detection area, the amount of delay incurred before the vehicle is recognized by a delay detector is a user-selectable value. Delay detection is a valuable capability that can be used with presence detection to avoid unnecessary calls for the green. A typical use is in side-street right-turn lanes where a delay value of about 10 seconds is usually enough to keep side-street vehicles that turn right on red from needlessly calling for the green.

DELAY DETECTION EXAMPLE
DELAY SET TO 6 SECONDS

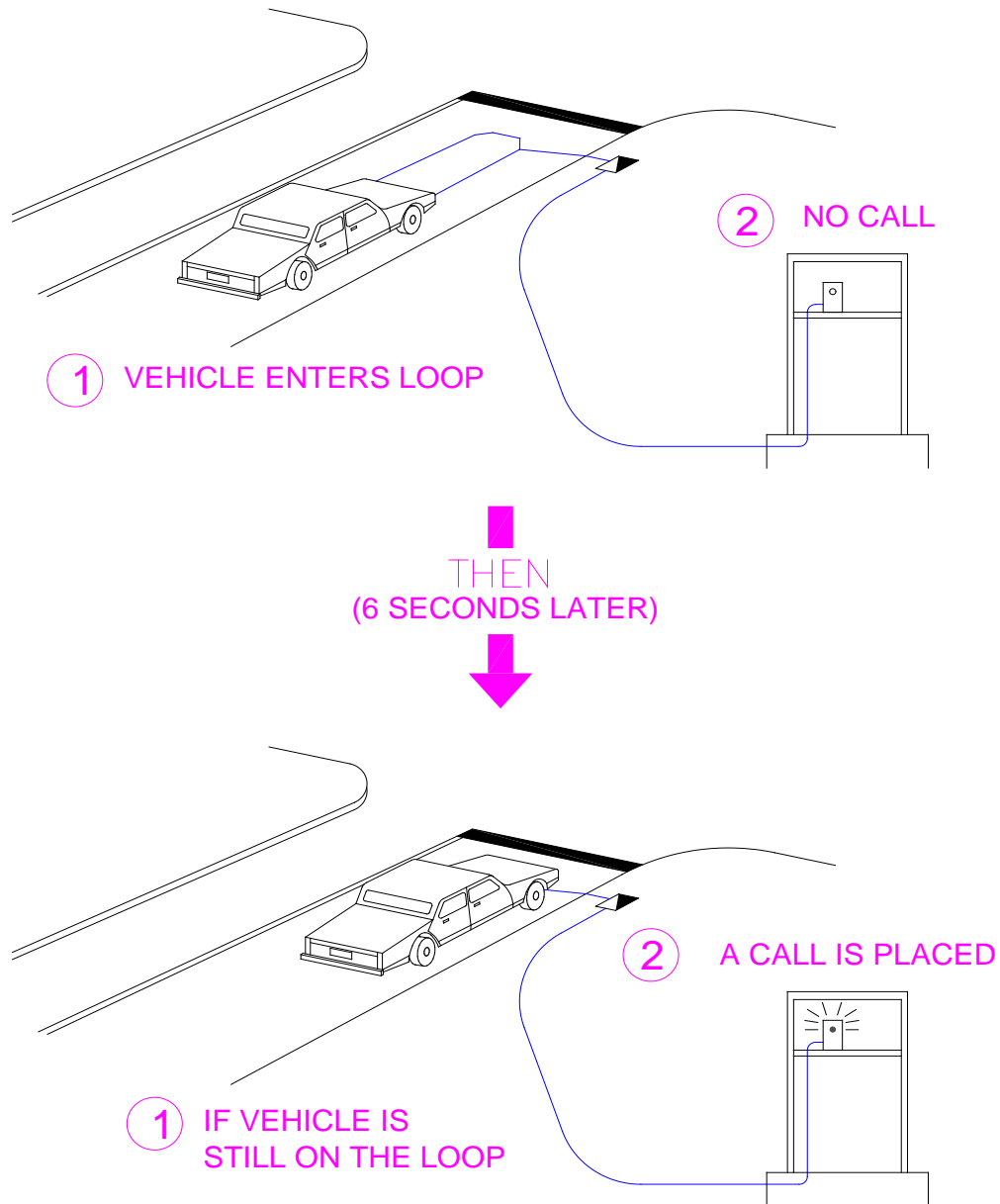

Detectors can also be purchased which allow the call to be extended even after the vehicle has left the detection area. The amount of this extension is also a user-programmable value. Extended call detectors are sometimes used to provide additional passage time for heavy truck traffic.

The detector harness must be properly wired in the controller cabinet to disarm the delay function when the phase, which that detector extends, has the green indication.

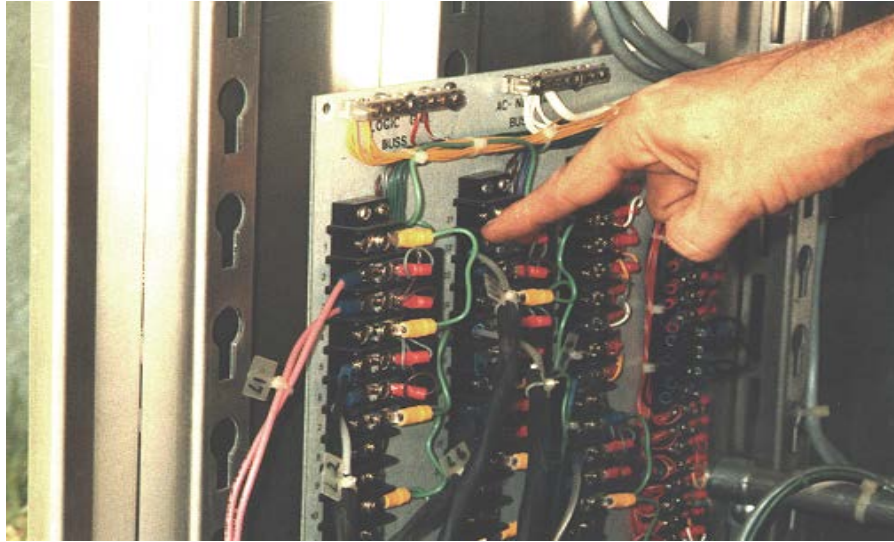

If this is not done the delay function will continue to operate during the green interval, causing the passage interval to time out prior to subsequent actuation and resulting in premature gap-out. The end result will be termination of the green even though a line of cars is still waiting to get thru the intersection.

Detectors can be purchased as stand-alone units, each with its own housing and power supply:



Or they can be purchased as rack-mounted units which share a common housing and power supply:

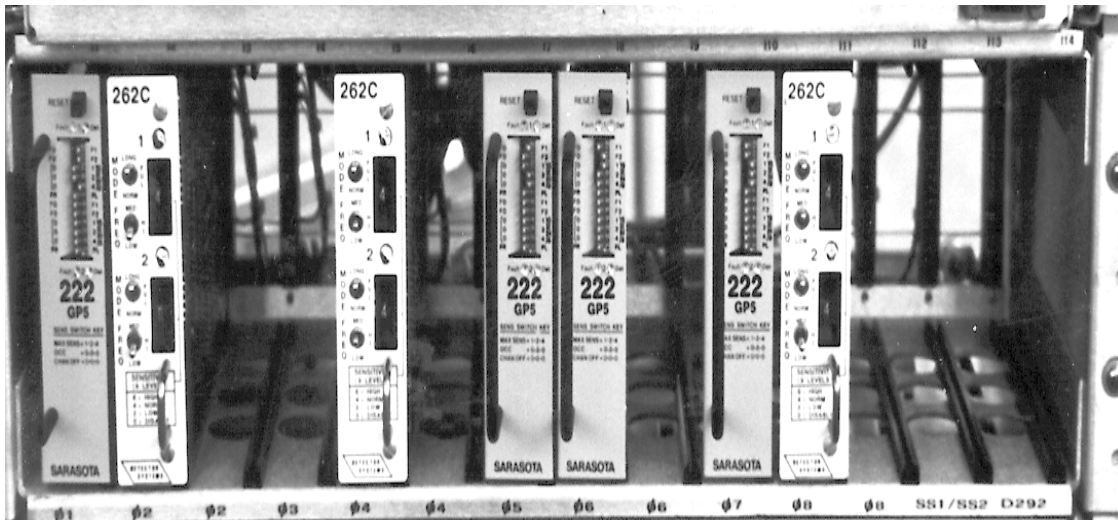

Detectors can also be purchased as either single-channel or multi-channel units. It is not unusual to find up to four channels on a multi-channel detector, with each channel monitoring a separate loop assembly.

Most older model detectors (many of which are still routinely encountered in the field) require the technician to fiddle with a knob on the front of the detector in order to manually "tune" the detector to its proper operating state. This is a somewhat cumbersome task that requires proper technique by the technician to obtain the desired result. Newer detectors are self-tuning and do not require this "fiddling".

DILEMMA ZONE PROTECTION

Two types of dilemma zones are discussed in the traffic engineering literature. The first is a Type I dilemma zone, and the discussion centers on the ability of a vehicle, upon receiving the yellow indication, to either enter the intersection before the red interval is displayed or stop before reaching the stop bar.

The second is a Type II dilemma zone, and the discussion centers on the need for a vehicle detection scheme that does not display the yellow indication to a motorist at a point on the intersection approach that would result in potentially erratic driving behavior. The Type II dilemma zone is addressed here.

At speeds of 30 mph and greater the driver encounters an area of indecision in advance of the stop line. If, while in this Type II "dilemma zone" (sometimes referred to as an "option zone"), the signal happens to turn yellow, the driver may hesitate in deciding whether to stop or continue through the intersection. A detection design that minimizes the probability that the yellow interval will be displayed while vehicles are in the dilemma zone is of benefit in reducing erratic driver behavior and associated accidents.

The dilemma zone has been formally defined as: the area in advance of the stop line that begins at a location where 90% of the drivers will stop while 10% of the drivers will continue through the intersection and ends at a location where only 10% of the drivers will stop while 90% of the drivers will continue through.

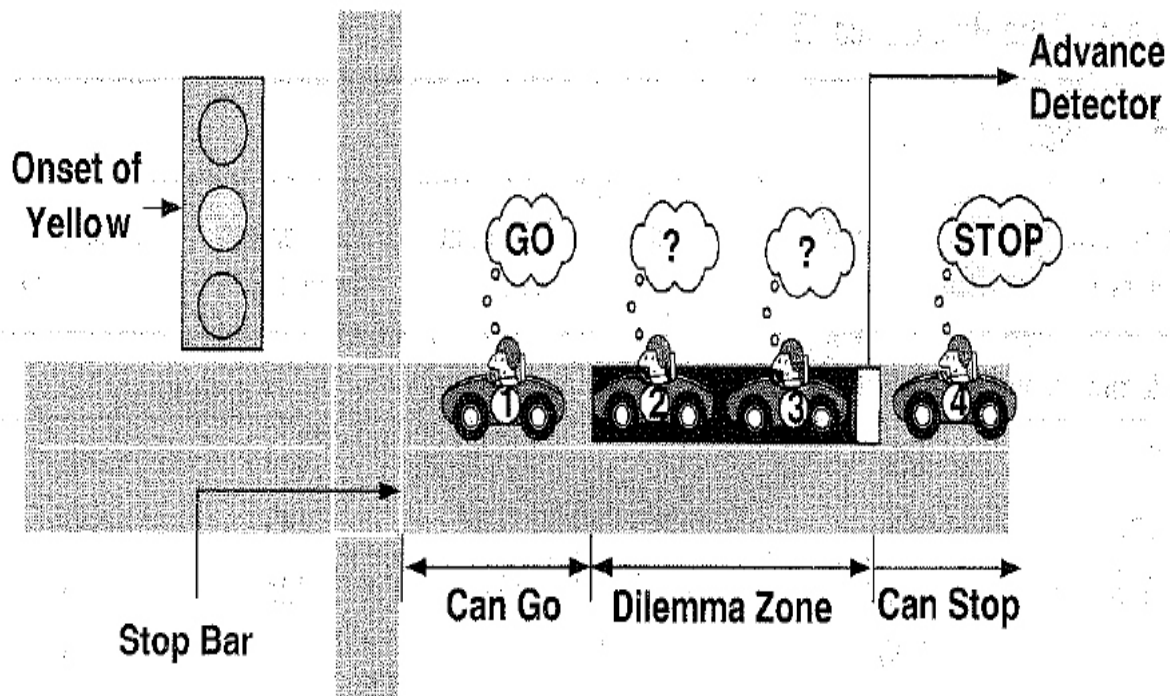

Research has indicated that the dilemma zone is longer at higher speeds (about 160 feet long at 55 mph) than at slower speeds (about 85 feet long at 30 mph). Research has also shown, and logic would concur, that the dilemma zone both begins further away from the intersection at higher speeds (it starts 400 feet from the intersection at 55 mph but only 175 feet from the intersection at 30 mph) and ends further away from the intersection at higher speeds (ending 240 feet from the intersection at 55 mph and 90 feet from the intersection at 30 mph).

A dilemma zone chart indicates the extent and location of the dilemma zone for various approach speeds:

Approach Speed	Start of Dilemma Zone	End of Dilemma Zone
30 mph	175' from stop bar	90' from stop bar
35 mph	220' from stop bar	100' from stop bar
40 mph	250' from stop bar	110' from stop bar
45 mph	300' from stop bar	165' from stop bar
50 mph	350' from stop bar	220' from stop bar
55 mph	400' from stop bar	240' from stop bar

The following detection design uses strategically spaced upstream loops to help pass motorists thru a dilemma zone having a 45 mph approach speed:

- First 6' x 6' Upstream Loop: 330' from stop bar
- Second 6' x 6' Upstream Loop: 200' from stop bar
- No stop bar loops
- Initial setting in controller: at least 18 seconds
- Passage setting in controller: 2.5 seconds
- Phase set to Minimum Recall

In this design, the minimum recall setting and the 18 second initial interval ensures that all vehicles stored between the stop bar and the nearest upstream loop are serviced and the 2.5 second passage interval ensures that vehicles travelling at or near the 45 mph approach speed will pass through the dilemma zone without the yellow being displayed.

Complete dilemma zone protection is never achieved because a few drivers will travel significantly faster or slower than the approach speed. Also, if the green is extended to the maximum interval for the approach, then the green will be terminated regardless of the status of the passage interval, which could result in the yellow being displayed to vehicles still in the dilemma zone.

PEDESTRIAN DETECTION

The primary pedestrian detection device is the manual push button.



When a pedestrian pushes the button, a call for pedestrian service is registered with the controller for the corresponding pedestrian phase. The pedestrian call is then serviced (the WALK indication is displayed) at the appropriate time in the signal cycle.

Pedestrian push buttons must now meet ADA (Americans with Disabilities Act) standards as well as MUTCD (Manual on Uniform Traffic Control Devices) requirements. The push button must be at least 2-inches in diameter and it should be conveniently located near the crosswalk to which it pertains. It should also be mounted at a height of approximately 3.5 feet (no more than 4 feet) and be reachable from a wheelchair positioned on the nearest sidewalk.

Some of the newer pedestrian push buttons have a confirmation light (referred to as a “pilot light”) which illuminates when the button is pushed, and stays illuminated until the pedestrians are serviced.



Since this button works just like an elevator call button (which lights up when a person pushes it and goes out when the elevator arrives), it has a familiar operation that the average person can understand. Having a lighted call indicator informs the pedestrian that their request for service has been recognized (with standard pedestrian buttons, no such acknowledgement is provided), thus reducing both the temptation to cross the street before the WALK indication is provided, and reducing the incentive for pedestrians to continue to "mash" the pedestrian button.

An accessible pedestrian detector is a special pedestrian push button assembly that produces an audible signal and that vibrates to indicate when the WALK indication is active (up to a maximum of 7 seconds). These detectors also have a tactile arrow located on the push button which indicates the crosswalk to which the button applies.



Some accessible pedestrian detectors provide additional features that may include Braille labels for street names, tactile crosswalk maps, extended pedestrian timing, and recorded information containing actual street names. All of these features are very helpful to people who are visually or hearing impaired.

Passive detection devices, such as overhead infrared units, ultrasonic units, laser scanners, microwave radar, video imaging, and piezoelectric mats, may also be used for pedestrian detection.



Microwave Radar

Passive devices detect the presence of a pedestrian without requiring the pedestrian to push a button.



Some passive devices can extend or shorten the pedestrian timing based on the crossing behavior of the pedestrian.